

WF S0377 NE/IXL

12NC: 859991580390

GTIN (EAN) code: 8003437601293

Whirlpool

SENSING THE DIFFERENCE

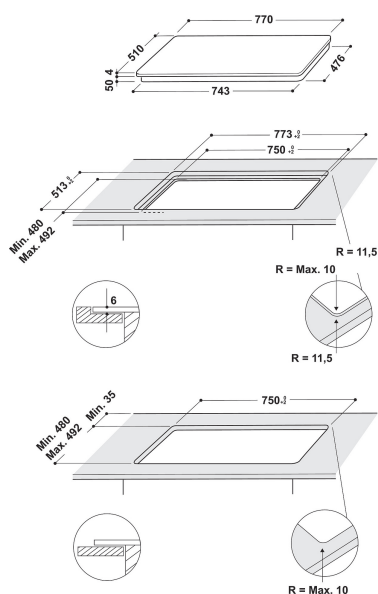
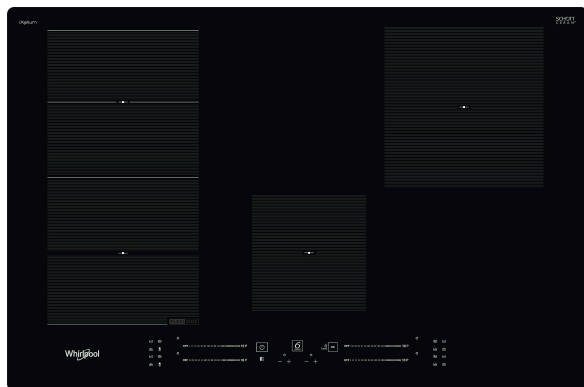

MAIN FEATURES

Product group	Hob
Construction type	Built-in
Type of control	Electronic
Type of control settings	-
Number of gas burners	0
Number of electric cooking zones	0
Number of electric plates	0
Number of radiant plates	0
Number of halogen plates	0
Number of induction plates	4
Number of electric warming zones	0
Location of control panel	Front
Basic surface material	Ceramic Glass
Main colour of product	Černá
Electrical connection rating (W)	7200
Gas connection rating (W)	0
Current (A)	31,3
Voltage (V)	220-240
Frequency (Hz)	50/60
Length of Electrical Supply Cord (cm)	120
Plug type	Ne
Gas connection	N/A
Width of the product	770
Height of the product	54
Depth of the product	510
Minimum niche height	30
Minimum niche width	750
Niche depth	480
Net weight (kg)	11.1
Automatic programmes	Ano

TECHNICAL FEATURES

Power on indicator	Ano
Number of indicators	4
Type of regulation	Induction
Type of lid	Without
Residual heat indicator	Separate
Main on/off switch	Ano
Safety device	-
Timer	Ano

ENERGETICKÝ ŠTÍTEK

Energy input

Electric